

BECLAWAT



71731 - Full Hinged In Vent Steel Weld-In Watertight Window

This heavy marine all weld-in mild steel or stainless steel watertight window is a full vent, hinging inward. It is available in custom shapes and sizes. The steel window frame is usually sandblasted and has weld-able primer to suit most specifications. Stainless available in 304 or 316 grade. Spigot depths range from 3", 4", 5" and 6". The opening panel is aluminum framed with retaining ring and is toggled down for a watertight seal. It will suit a glass thickness of 10mm or thicker.

The panel is hinged at the side or bottom and can come with a quadrant arm to hold the window open when hinged at the bottom or an eye to hook the window panel to the ceiling when top hinged.

Pictured window has radius corners with a brass retaining ring. Aluminum retaining rings with other finishes are available.

Glass is clear tempered. Other tinted and various glass thickness options are available. Heated glass can be adapted to this type of frame.

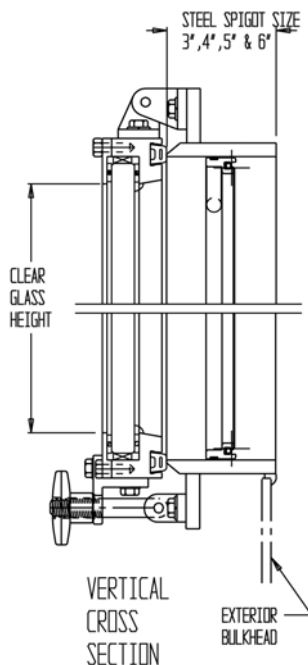

For more information
Call: 613-966-5611

Email:
info@beclawat.com



BECLAWAT Manufacturing Inc.
90 Hanna Crt. Belleville, ON K8P 5H2 Canada
Ph: 613-966-5611 Fx: 613-966-0878 www.beclawat.com

