

# BECLAWAT



## 72348 - Shaped Horiz. Alum. Sliding Clamp-on/Bolt-on



This light marine aluminum horizontal sliding window is available in custom shapes and sizes.

The frame style is has a clamp-on style frame. It will suit a glass thickness of **6mm only**.

Some features of this window include the forward glass sliding open to the rear and a removable sliding screen.

Pictured window has a clear anodized finish custom shaped to suit the customer's application. Other finishes are available.

This window has a removable sliding screen.

The glass can be tinted. Tempered glass is preferred.

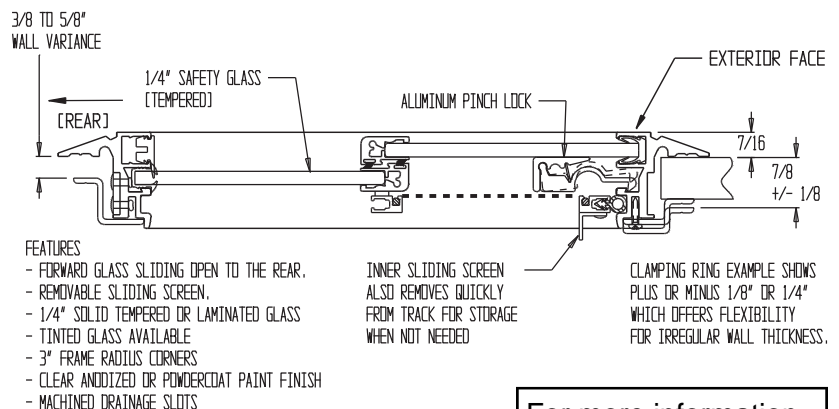

For more information  
Call: 613-966-5611

Email:  
info@beclawat.com



**BECLAWAT** Manufacturing Inc.  
90 Hanna Crt. Belleville, ON K8P 5H2 Canada  
Ph: 613-966-5611 Fx: 613-966-0878 www.beclawat.com

